

# Tachogenerators

Blind hollow shaft  $\varnothing 12$  to  $\varnothing 16$  mm

Housing  $\varnothing 85$  mm, bearingless configuration

## GT 7



GT 7

### Technical data - electrical ratings

Reversal tolerance	$\leq 0.1$ %
Linearity tolerance	$\leq 0.15$ %
Temperature coefficient	$\pm 0.05$ %/K (open-circuit)
Isolation class	B
Calibration tolerance	$\pm 5$ %
Climatic test	Humid heat, constant (IEC 60068-2-3, Ca)
Armature-circuit time-constant	$< 4$ $\mu$ s
Open-circuit voltage	10...60 mV per rpm
Interference immunity	EN 61000-6-2
Emitted interference	EN 61000-6-3
Approval	CE

### GT 7.08

Performance	0.3 W (speed $\geq 5000$ rpm)
-------------	-------------------------------

### GT 7.16

Performance	0.6 W (speed $\geq 5000$ rpm)
-------------	-------------------------------

### Features

- Temperature compensation of tacho voltage as standard
- Open circuit voltage 10...60 mV per rpm
- Blind hollow shaft  $\varnothing 12$ ...16 mm
- High signal quality due to patented LongLife technology
- Low moment of inertia
- No auxiliary energy source required

### Technical data - mechanical design

Size (flange)	$\varnothing 70$ mm
Shaft type	$\varnothing 12$ ...16 mm (blind hollow shaft)
Protection DIN EN 60529	IP 55
Torque	1.5 Ncm
Materials	Housing: stainless steel / plastic Shaft: stainless steel
Operating temperature	-30...+130 °C
Resistance	IEC 60068-2-6 Vibration 10 g, 10-2000 Hz IEC 60068-2-27 Shock 100 g, 6 ms
Connection	Screw terminal connector Cable 0.6 m

### GT 7.08

Rotor moment of inertia	0.4 kgcm <sup>2</sup>
Weight approx.	110 g

### GT 7.16

Rotor moment of inertia	0.55 kgcm <sup>2</sup>
Weight approx.	180 g

# Tachogenerators

Blind hollow shaft  $\varnothing 12$  to  $\varnothing 16$  mm  
Housing  $\varnothing 85$  mm, bearingless configuration

GT 7

## Part number

GT7.08L/4

Open-circuit voltage  
10 10 mV per rpm  
20 20 mV per rpm  
30 30 mV per rpm

GT7.16L/4

Open-circuit voltage  
40 40 mV per rpm  
60 60 mV per rpm

## Data according to type

Type	Off-load voltage $U_0$ [mV/rpm]	Minimum load required depending on speed range [rpm]			Maximum operating speed $n_{max}$ [rpm]	Armature resistance $R_A$ (20°C) [ $\Omega$ ]	Armature inductance $L_A$ [mH]
		0-3000	0-6000	0- $n_{max}$			
GT7.08L/410	10	$\geq 5$	$\geq 12$	$\geq 27$	9000	60	20
GT7.08L/420	20	$\geq 20$	$\geq 48$	$\geq 108$	9000	230	80
GT7.08L/430	30	$\geq 45$	$\geq 108$	$\geq 243$	9000	550	180
GT7.16L/440	40	$\geq 40$	$\geq 96$	$\geq 216$	9000	410	160
GT7.16L/460	60	$\geq 90$	$\geq 215$	$\geq 223$	6100	760	360

Superimposed ripple (for  $\tau_{RC} = 0.3$  ms):  $\leq 0.6\%$  (peak-peak)  $\leq 0.25\%$  (rms)

## Replacement switching diagram

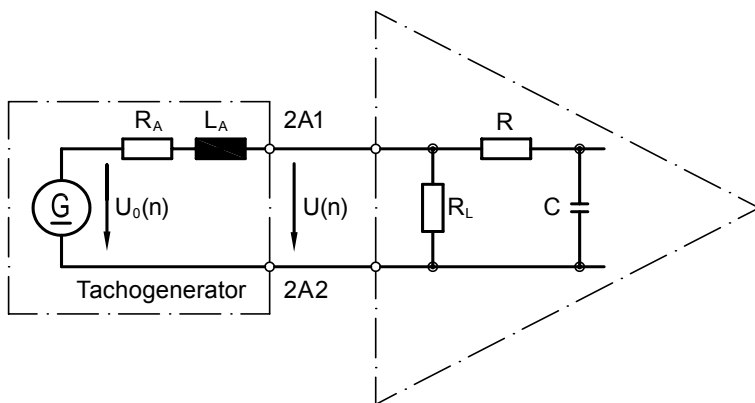

$$\tau_{RC} \approx R \cdot C \quad \tau_A \approx \frac{L_A}{R_L}$$

Polarity for positive rotating direction: 2A1: + 2A2: - (VDE)

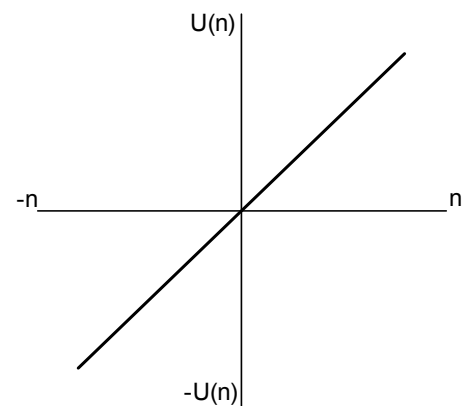

$$U(n) = U_0(n) \frac{R_L}{R_A + R_L} \approx U_0(n) \text{ for } R > R_L \gg R_A$$

# Tachogenerators

Blind hollow shaft  $\varnothing 12$  to  $\varnothing 16$  mm

Housing  $\varnothing 85$  mm, bearingless configuration

## GT 7

### Terminal assignment

View A - Connecting terminal

Polarity for positive direction of rotation

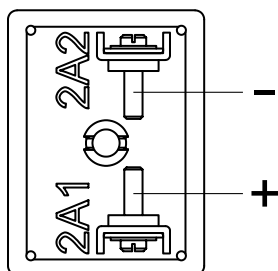

### Accessories

Mounting cone

Carbon brushes

# Tachogenerators

Blind hollow shaft  $\varnothing 12$  to  $\varnothing 16$  mm

Housing  $\varnothing 85$  mm, bearingless configuration

GT 7

## Dimensions

GT 7.08 - Open-circuit voltage 10...30 mV per rpm

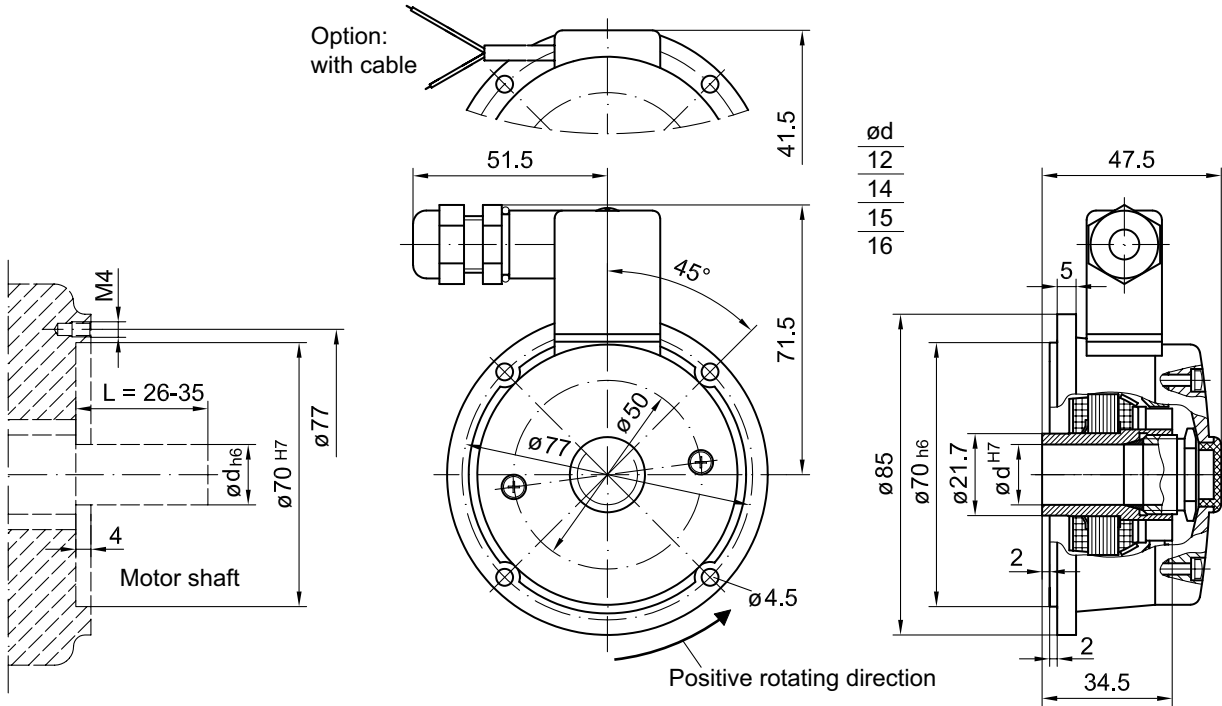

GT 7.16 - Open-circuit voltage 40...60 mV per rpm

